

Arnaldo Brandolini, et. al.. "Energy Measurement."

Copyright 2000 CRC Press LLC. <<http://www.engnetbase.com>>.

Energy Measurement

Arnaldo Brandolini

Politecnico di Milano

Alessandro Gandelli

Politecnico di Milano

42.1 Dc Energy Measurement

42.2 Ac Induction Energy Meters

42.3 Static Energy Meters

The Electronic Energy Meter • The Conditioning System for dc Electronic Energy Meters • Voltage and Current Adapters for ac Electronic Energy Meters • Electronic-Analog Energy Meters with Digital Output • All-Digital Energy Meters

42.4 Accuracy of Energy Meters

Energy is one of the most important physical quantities in any branch of science and engineering and especially in electrical engineering. Energy exchange processes lead to the study of electric networks from the physical point of view and allow an in-depth knowledge of power transfer within the electrical world and between electric and other forms of energy.

The definitions of energy and power represent the starting point for any successive study.

1. Energy is the amount of work that the system is capable of doing.
2. Power is the time rate of doing work.

Energy can be mathematically defined as the definite integral of the power over a given time interval Δt .

The power available in a two-terminal section of an electric circuit is given by the product of the voltage across the terminals and the current flowing through the section itself ($p = vi$). The electric energy (E) flowing through the same section is defined by the integral of the power over the observation interval:

$$E(\Delta t) = \int_{t_0}^{\Delta t + t_0} p dt \quad (42.1)$$

For this reason, energy measurement is a dynamic measurement, which means it varies with time. The energy measurement unit is the Joule (J); but for the electric energy, the Watthour (Wh) is most common.

The electrostatic energy is defined as the product of the electric charge and the difference of electric potential.

Electricity is generated from different forms of energy (thermal, hydraulic, nuclear, chemical, etc.); after electric transfer and distribution processes, it is converted to other forms of energy. The main feature of electric energy is the simplicity by which one can transfer it over long distances, control the distribution, and measure energy consumption.

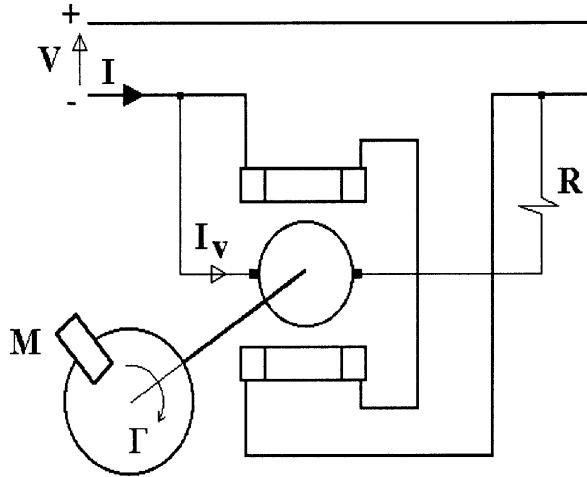

FIGURE 42.1 The electrodynamic dc energy meter; M = permanent magnet.

42.1 Dc Energy Measurement

The simplest way to perform this measurement is to measure voltage and current and then compute the product:

$$E = VI\Delta t \quad (42.2)$$

where Δt is the observation interval measured by means of a chronometer or a time counter.

Note that dc systems are limited to a restricted number of applications in power systems, as, for example: electric traction, electric drives, electrochemical power plants, and for HVDC transmission system in limited operating conditions. All these cases, nevertheless, allow energy measurement either on the dc or ac side of the network.

The dc energy measurement has been performed in the past by means of different methodologies and instruments such as electrodynamic measurement devices (Electrodynamics dc Energy Meter) operating as an integrating wattmeter (Figure 42.1). This measuring instrument is built using a small dc motor without iron, whose magnetic field is generated by the line current flowing through a coil arranged as the fixed part of the system. The rotor is connected in series with an additional resistor and is powered by the line voltage (V). Because of the lack of the iron in the magnetic circuit, the rotor magnetic flux ϕ is strictly proportional to the current I .

The rotor current (derived from the line voltage) is:

$$I_v = (V - E) / R \quad (42.3)$$

where $E = k_1\Gamma\phi$ is the emf induced by the angular speed Γ , and R is the total resistance of the voltage circuit. It is possible to make the emf E negligible because of low angular speed Γ , limited amplitude of the flux ϕ , and a significant resistance R . In this way, Equation 42.3 becomes:

$$I_v \approx V / R \quad (42.4)$$

The torque C_m provided by the motor can be written:

$$C_m = k_2\phi I_v \approx k_3IV / R = k_4P \quad (42.5)$$

C_m is therefore approximately proportional to the power P flowing through the line. It is necessary, however, to remember that this torque could create a high angular speed to the rotor, because of constantly incrementing speed. In order to maintain dynamic equilibrium, a simple aluminum disk mounted on the rotor axis and placed in a constant magnetic field provided by a permanent magnet M , is added to the dc motor system. In this way, the induced currents in the disk introduce a damped torque proportional to the angular speed Γ , so, at equilibrium, there is a linear dependence of Γ on the power P . Thus,

$$E = \int_{\Delta t} P dt = k_5 \int_{\Delta t} \Gamma dt \quad (42.6)$$

A mechanical counter transfers the rotating motion into a digital representation of the total energy consumed during a specific time interval Δt in the power system.

42.2 ac Induction Energy Meters

The most traditional and widely used ac energy meter is the *induction meter*. This device is built by means of three electric circuits, magnetically coupled, two of them fixed and one rotating around the mechanical axis of the system. Figure 42.2 shows the two fixed circuits, (1) and (2), which are the voltage and the current coils. The third circuit is the rotating disk (3), generally made of aluminum, mounted on a rigid axis (4) transmitting the disk rotation to a mechanical counter (6), which provides the energy display.

The fixed circuits (1) and (2) provide magnetic fluxes interacting with the rotating disk. Fixed circuits (1) and (2) form a C shape and the disk is placed in their iron gaps. Another similar structure, arranged using a permanent magnet (5), is placed over the disk as well. The magnetic fluxes generated by the voltage and current circuits are at the same frequency and are sinusoidal. They induce currents in the rotating disk that, by means of a cross-interaction with the two generating fluxes, provide a mechanical torque acting on the disk. The torque is given by:

$$C_m = KVI \sin(\alpha) \quad (42.7)$$

where C_m = Mechanical torque

K = System constant

V = rms of the value of the applied voltage

I = rms of the value of the applied current

α = Phase angle between the fluxes generated by V and I

The acting torque causes the disk to rotate around its axis. This rotation reaches a dynamic equilibrium by balancing the torque C_m of the voltage and current coils and the reacting torque generated by permanent magnet. The resulting angular speed, Γ , is therefore proportional to the flowing power if:

- The angular speed Γ of the disk is much smaller than the voltage and current frequency ω
- The phase difference between the voltage and current fluxes is equal to $\alpha = \pi - \phi$, where ϕ is the phase difference between the voltage and current signals

The angular speed of the rotating disk can be written as:

$$\Gamma = (1/k) \omega (R_3 / Z_3^2) (M_1 I) (M_2 V / Z_2) \cos(\phi) = K P \quad (42.8)$$

where Γ = Angular speed of the rotating circuit (conductor disk), in rad s^{-1}

K = Instrument constant, in $\text{rad s}^{-1} \text{W}^{-1}$

P = Mean power in the circuit, in W

$1/k$ = Constant, in $\Omega \text{V}^{-2} \text{s}^{-2}$

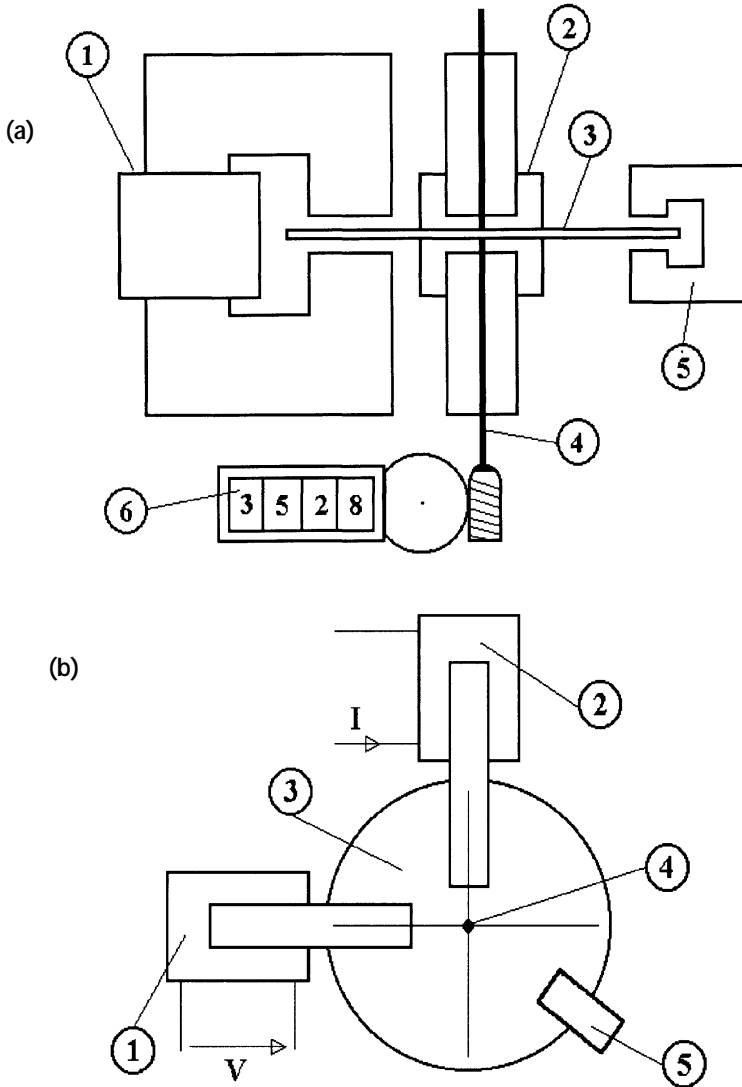

FIGURE 42.2 (a) Side View of an ac induction energy meter: (1) voltage coil and magnetic circuit; (2) current coil and magnetic circuit; (3) aluminum rotating disk; (4) disk axis; (5) permanent magnet; (6) mechanical display. (b) Top view of an ac induction energy meter: (1) voltage coil and magnetic circuit; (2) current coil and magnetic circuit; (3) aluminum rotating disk; (4) disk axis; (5) permanent magnet.

- ω = Voltage and current frequency, in rad s^{-1}
- R_3 = Equivalent resistance of the rotating disk, relative to the induced current fields, in Ω
- Z_3 = Equivalent impedance of the rotating disk, relative to the induced current fields, in Ω
- $(M_2 V/Z_2)$ = rms value of the common flux related to the circuits n. 1 and 3, in Wb
- $(M_1 I)$ = rms value of the common flux related to the circuits n. 2 and 3, in Wb
- Z_2 = Impedance of the voltage circuit (n. 1), in Ω
- V = rms value of the applied voltage, in V
- I = rms value of the applied current, in A
- ϕ = Phase difference between current and voltage signals

The integral of Γ over a defined period Δt is proportional (with enough accuracy) to the energy flowing in the power circuit. Thus, it is true that the instrument constant K is strictly related (but not proportional) to the signal frequency ω .

42.3 Static Energy Meters

The development of electronic multipliers led to their use in energy meters that directly multiply voltage by current. In their first version, electronic multipliers used analog components (operational amplifiers, resistors, capacitors, etc.), while recent devices use digital components and programmable logic systems. Voltage and current signals are processed to obtain a signal proportional to the real power flowing into the line. The result is integrated over the observation time in order to calculate the *measured* energy. The devices based on these components are completely static (i.e., they do not have any moving parts). Moreover, because these electronic components have a frequency range from dc to high frequencies, instruments based on them can be applied to dc, ac, or distorted power systems (some care must be taken in order to provide a correct sampling of signals in all-digital systems).

There are many different prototypes in this class of energy meters. The first realizations were based on analog multipliers and, even if they were not able to replace the traditional induction energy meters, they represented a good solution for all those applications where an increased accuracy was required (up to 0.2%). Now, more sophisticated digital instruments are under design and development, based on dedicated structures mainly implementing DSPs (digital signal processors) as powerful tools for numerical computation and sigma-delta analog-to-digital converters (ADCs) in order to optimize the conversion process.

Many of these instruments can be analyzed by means of the following functional descriptions.

The Electronic Energy Meter

Figure 42.3 shows the block diagram of an electronic energy meter. The main feature of this type of instrument is the presence of voltage inputs on both voltage and current channels, because the electronic circuitry accepts only voltage signals. It has negligible current consumption from the system under measurement, due to high input impedance. Moreover, the maximum amplitude level of the input signal must be limited to around 5 V to 15 V. For this reason, the conditioning apparatus must guarantee the correct current-to-voltage transformation and the proper voltage reduction. This type of instrument can work at dc (which omits voltage and current transformers) or ac power systems and can also measure energy from distorted signals.

The Conditioning System for dc Electronic Energy Meters

The basic blocks of the conditioning system for a dc energy meter are formed from a voltage divider for the voltage input, and a shunt for the current input. After these passive components, two preamplifiers are usually introduced before the processing system. The current preamplifier is very important because:

1. The voltage output level of the current shunt is very low, even at full scale (≤ 1 V).
2. Many times, the current input has to support overloaded signals; the presence of a variable gain amplifier allows acceptable working conditions for the system.
3. It can be used to implement an active filter before signal processing.

Voltage and Current Adapters for ac Electronic Energy Meters

The most common devices to process ac signals for static energy meters are the traditional voltage and current transformers. They must be made with proper components to achieve the right amplitude of the voltage inputs (by nonreactive shunts for the current transformers, and nonreactive voltage dividers for

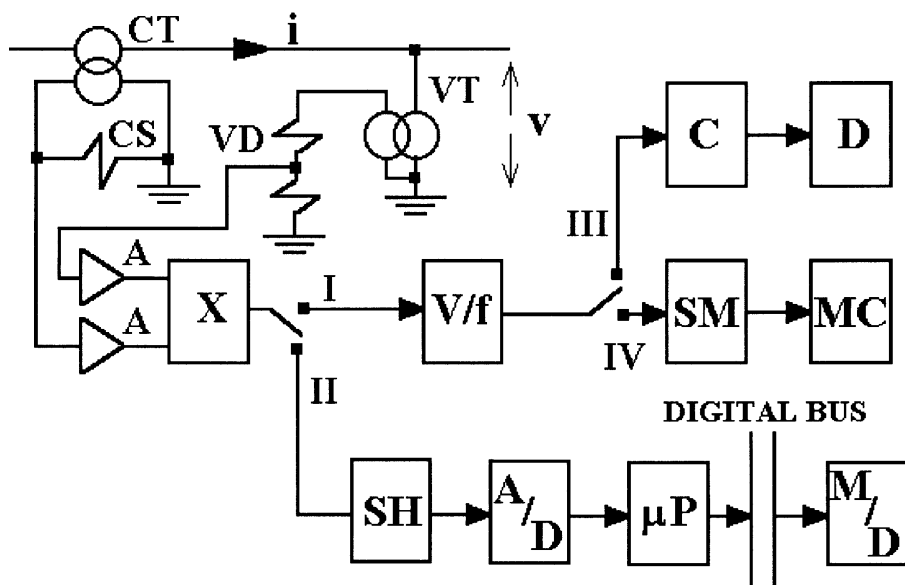

FIGURE 42.3 Electronic energy meter. Mechanical display option (I to IV). Electronic display option (I to III). Electronic display option and digital processing of the power signal (II). CT, current transformer; VT, voltage transformer; CS, current shunt; VD, voltage divider; A, analog signal processing block; X, multiplier; V/f, voltage-to-frequency converter; SM, step motor; MC, mechanical counter; C, electronic counter; D, display; SH, sample and hold; A/D, analog-to-digital converter; μP , microprocessor (CPU); M/D, memory and display.

the voltage transformers). After the transformers, and related devices, a second block, based on electronic amplifiers, provides the final analog processing of the input signals, as for the dc conditioning systems. It is useful to introduce this second processing element because analog filters are generally required when the input signals need to be digitally processed.

Electronic-Analog Energy Meters with Digital Output

These instruments provide the product of the two input signals (both voltages) through an analog multiplier that evaluates a voltage output proportional to the power of the input signals. This output can be followed by a filtering block.

The output signal is proportional to the instantaneous electric power flowing through the line. To calculate the energy, it is now necessary to complete the process by integrating over the observation time. This last procedure can be performed in two different ways.

1st procedure: The power signal at the output of the analog multiplier is applied to the input of a voltage frequency converter. Thus, the power information is converted from a voltage level to the frequency pulse sequence, for which the counting process performs the integration of the power in the observation interval, i.e., the measurement of energy.

The final measurement can be performed by means of an electronic counter with digital display or using a dc step motor incrementing the rotor angular position every pulse by a fixed angular increment. The rotor position is shown by a mechanical counter (similar to the system mounted on the induction energy meters) indicating the total number of complete rotations performed by the system, proportional to the energy of the system under measurement. This second arrangement is normally adopted because it allows a permanent record of the energy information, which is not subject to possible lack of electric energy as in the first case.

2nd procedure: This arrangement is based on an analog-to-digital converter (ADC) connected to the output of the analog multiplier. The sampling process is driven by an internal clock. Thus, the ADC

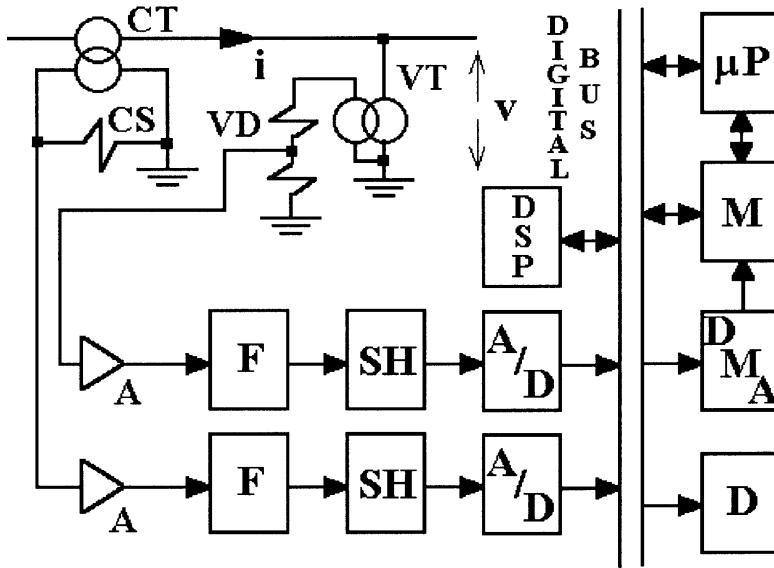

FIGURE 42.4 All-digital energy meter. CT, current transformer; VT, voltage transformer; CS, current shunt; VD, voltage divider; A, analog signal processing block; F, analog electronic filter; SH, sample and hold; A/D, analog-to-digital converter; μ P, microprocessor (CPU); M, memory; DSP, digital signal processor; DMA, direct memory access circuit; D, display.

provides uniform sampling over the signal period and, under the condition imposed by the sampling theorem, the sum of the samples is proportional to the integral of the power signal, i.e., to the energy during the observation interval.

The calculation is performed by means of a dedicated CPU and then the results are sent to the digital memory to be stored and displayed. They can also be used to manage any other automatic processes based on the energy measurement. For this purpose, data are available on a data bus (serial or parallel) connecting the measuring system with other devices.

The sampling process is performed by a Sample & Hold circuit.

All-Digital Energy Meters

The most advanced solution for energy measurement can be found in all-digital meters (Figure 42.4), where both the voltage and current signals are sampled before any other processing. Thus, the data bus presents the sampled waveforms in digital form, giving the opportunity to perform a wide choice of digital signal processing on the power and energy information. Both sampling devices are driven by a CPU, providing synchronized sampling signals.

Sometimes, the system is equipped with a DSP capable of providing hardware resources to implement real-time evaluation of complex parameters (i.e., signal transforms) of the signal and energy measurement. Dedicated hardware and software performing instrument testing are also integrated into the meter to complete the device with the most advanced features.

Filters able to meet the sampling theorem requirements, programmable gain amplifiers, and Sample & Hold circuits generally precede the ADCs.

Data management is arranged in two possible ways: sending the sampled data directly to the processing system for calculations, or accessing the memory using DMA procedures, so the data string for a specific time period is first stored and then used for computation of energy and related parameter values. Final results of this computation are then available on the system bus to be sent to the other system resources or to be displayed.

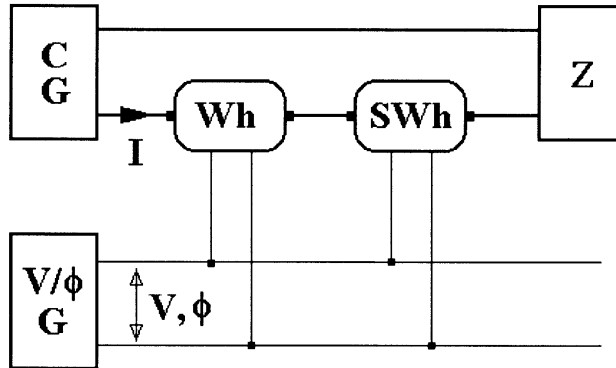

FIGURE 42.5 Testing circuit arrangement to compare an industrial meter (Wh) with a standard energy meter (SWh). CG, variable-amplitude current generator; $V/\phi G$, variable-amplitude and phase voltage generator; Z, load impedance.

42.4 Accuracy of Energy Meters

Accuracy of energy meters is defined by means of relative parameters (in percent) obtained from a testing process by powering the instrument with a constant (nominal) voltage signal and a variable current signal (5, 10, 20, 50, 100, 120% of the nominal value). The testing procedures are performed by comparing the meter under test with a standard meter (Figure 42.5), or using equivalent methods.

The accuracy of commercial electromechanical (induction) energy meters is generally around 2%. Energy meters with accuracies of 1% have also been built. Electronic energy meters have a better accuracy, generally between 0.5% and 0.2%.

Further Information

- S. Kusui and T. Nagai, A single-phase 3-wire watt-to-pulse frequency-converter using simple PWM and its accuracy analysis, *IEEE Trans. Instrum. Meas.*, 43, 770–774, 1994.
- P. Bosnjakovic and B. Djokic, Reactive energy measurement using frequency controlled analog-to-pulse-rate converter, *Archiv fur Elektrotechnik*, 75, 131–135, 1992.
- B. Djokic, P. Bosnjakovic, and M. Begovic, New method for reactive power and energy measurement, *IEEE Trans. Instrum. Meas.*, 41, 280–285, 1992.
- J. C. Montano, A. Lopez, M. Castilla, and J. Gutierrez, DSP-based algorithm for electric-power measurement, *IEE Proc. A, Sci. Meas. Technol.*, 140, 485–490, 1993.
- C. V. Drisdale and A. C. Jolley, *Electrical Measuring Instruments*, 2nd ed., New York: John Wiley & Sons, 1952.
- F. K. Harris, *Electrical Measurements*, New York: John Wiley & Sons, 1952.
- L. Schnell (ed.), *Technology of Electrical Measurements*, New York: John Wiley & Sons, 1993.
- L. Finkelstein and K. T. V. Grattan (eds.), *Concise Encyclopedia of Measurement & Instrumentation*, New York: Pergamon Press, 1994.